

# What is EXEMPT from soil erosion regulations?

A residential property owner may conduct the following activities on individual residential property owned and occupied by him or her and is not required to obtain a permit under Part 91 if the earth change activities do not result in or contribute to soil erosion or sedimentation of the waters of the state or a discharge of sediment off-site [onto neighboring properties]. These activities are:

Farming: plowing or tilling of land for the purpose of crop production or harvesting of crops.

Gardening: all residential gardens, unless the natural elevation is raised. [Bringing in fill dirt.]

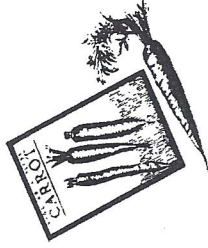

Stump and Root Removal: if tree and shrub stump removal does not exceed 100 sq ft.

Post Hole Digging: for fencing, decks, utility posts, mail boxes or similar applications – if no additional grading is done.

If stabilized within 24 hrs property owners may:

- Plant trees, shrubs, or other similar plants.
- Temporarily stockpile of soil, sand, or gravel not greater than a total of 10 cubic yards on the property if the stockpiling occurs at least 100 feet from the waters of the state.

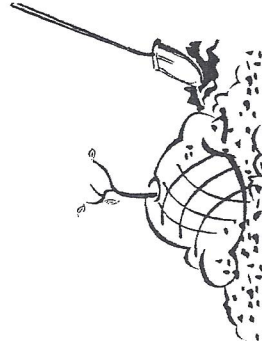

- Seawall maintenance that does not exceed 100 square feet.

- Seed or reseed lawns of less than 1 acre if the seeded area is at least 100 feet from the waters of the state.
- Seed or reseed lawns closer than 100 feet from the waters of the state if the area to be seeded or reseeded does not exceed 100 square feet.

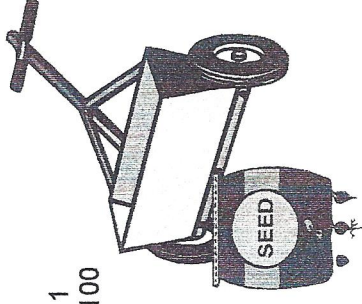

Beach nourishment projects permitted under part 325 of Act No. 451.

Normal road and driveway maintenance: such as grading or leveling, that does not increase the width or length of the road or driveway and that will not contribute sediment to lakes or streams.

Any earth change of a minor nature: that is stabilized within 24 hours of the initial earth disturbance and that will not contribute sediment to lakes or streams.

All of these exemptions listed here are not exemptions from enforcement procedures if the activities cause erosion or sedimentation in waters of the state.

Further questions about the Soil Erosion Regulations and Program should be directed to



Lapeer County Health Department  
Environmental Health Division  
810-667-0392  
[www.lchd.lapeer.org](http://www.lchd.lapeer.org)